

Tunable and frequency-stabilized CO₂ waveguide laser

Yangwu Ma

Di Liang*

Zhejiang University

Centre for Optical and Electromagnetic
Research

State Key Laboratory for Modern Optical
Instrument

Hangzhou, China, 310027

Abstract. The optogalvanic effect (OGE) of CO₂ waveguide lasers and CO₂ lasers stabilized by the OGE and tuned by the compound cavity are investigated. The laser operates at 60 emission lines and the maximum single line power is 8 W. The stability of the laser in long-term operation is better than 0.8%. © 2002 Society of Photo-Optical Instrumentation Engineers. [DOI: 10.1117/1.1518033]

Subject terms: frequency stabilization; optogalvanic effect; compound cavity tuning.

Paper 020060 received Feb. 27, 2002; revised manuscript received May 1, 2002; accepted for publication May 7, 2002.

1 Introduction

A study of a CO₂ laser stabilized by the optogalvanic effect (OGE) and tuned by the compound cavity is presented in detail in this paper. According to our study, we find that it can achieve not only a continuous tuning using the grating compound cavity, but also a stabilized frequency and power using the OGE of CO₂ waveguide lasers. The combination of these two points is an effective way to develop a new type of CO₂ waveguide lasers with stabilized frequency, good tunability, and other favorable functions.

This study shows that the amplitude, sensitivity, frequency response, and SNR of a CO₂ molecule increase dramatically with the enhancement of working air pressure. The later mathematical expression formula induced through the rate equation of the CO₂ laser level confirms our experimental results as well.

Combining our previous study of CO₂ waveguide lasers with a grating compound cavity,¹ we set up a tunable and frequency-stabilized CO₂ waveguide laser system. The compacted structure and the continuously tunable frequency and power are the most obvious advantages for a compound cavity. The largest single line power is 8 W and the output of 60 emission lines are obtained with the change of the coupling efficiency of a coupling cavity and the incidence angle of a compound cavity grating. In the processes of frequency stabilization and branch selection, which are controlled by an advanced computer center, a long-term power stability better than 0.8% and a frequency stability around 10⁻⁹ were obtained.

2 OGE of CO₂ Waveguide Lasers

2.1 Expression of the Optogalvanic Currents

Based on the operation of a CO₂ molecule laser,²⁻⁴ the mathematical expression formulas of the optogalvanic sig-

nal total response $S(t)$ and amplitude $R(\omega)$ can be as the following, which are induced by the rate equation of the CO₂ molecule laser level:

$$S(t) = S_{01}[1 - \exp(-t/\tau_{1A})] - S_{02}[1 - \exp(-t/\tau_{2A})], \quad (1)$$

$$R(\omega) = \frac{S_{01}\tau_{1A}^{-1}}{\omega^2 + \tau_{1A}^{-2}} - \frac{S_{02}\tau_{2A}^{-1}}{\omega^2 + \tau_{2A}^{-2}}. \quad (2)$$

Assuming ω_c as the roll-back point of the frequency modulation, i.e., $R(\omega_c) = 0$, we have

$$\omega_c = (S_{01}/S_{02})^{1/2}/(\tau_{1A}/\tau_{2A})^{1/2}. \quad (3)$$

In Eqs. (2) and (3), S_{01} and S_{02} are the high-frequency response part and the low-frequency response part of the optogalvanic signal, respectively; τ_{2A} and τ_{1A} are the relaxation times of the upper level and lower level of the CO₂ molecules, respectively; t is the system light field function time; and ω is the light field modulating frequency.

2.2 Experimental Measurement for the Optogalvanic Signals of CO₂ Waveguide Lasers

Figure 1 is the experimental setup of a CO₂ waveguide laser stabilized by OGE and tuned by a grating compound cavity. The waveguide tube is 30 cm long; the tube diameter is 3 mm; the ratio of the mixed gases CO₂, N₂, He, and Xe is 4:3:16:1, and the air pressure varies from 20 to 100 Torr. For the each air pressure, the working current can vary from 2 to 15 mA and the truncated frequency is between 20 and 2000 Hz.

2.2.1 Relationship of optogalvanic signals and the working pressure and the modulating frequency

Figures 2 and 3 represent the relationship of optogalvanic signals and the working pressure and the modulating frequency. Our study shows that ω_c shifts toward a higher frequency with an increase of the working air pressure be-

*Current address: Univ. of Notre Dame, Dept. of Elec. Engineering, 275 Fitzpatrick Hall, Notre Dame, IN 46556.

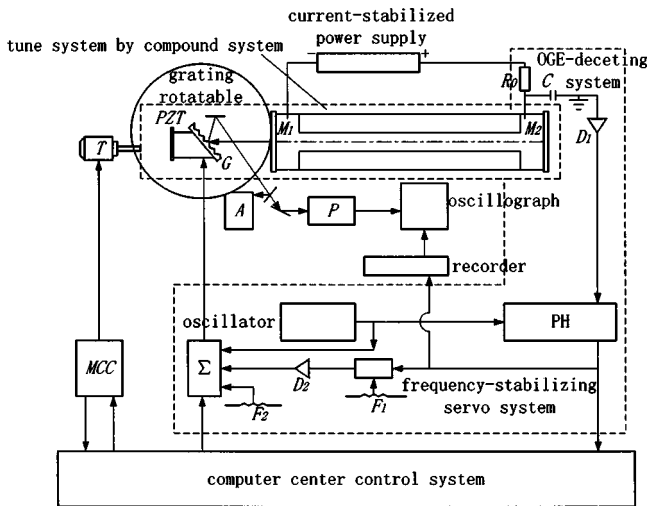

Fig. 1 Experimental setup of a CO₂ waveguide laser stabilized by OGE and tuned by a grating compound cavity: R₀C; OGE-deceting network; D₁, frequency-selection preamplifier; D₂, voltage change and power amplifier; F₁, differential compensation amplifier; F₂, bias rectifier; Σ, sign integration; PH, phase-detecting and synchronous integrating circuit; T, stepper motor; MCC: control circuit of stepper motor; A, CO₂ spectrum analyzer; P, power meter; G, grating; PZT, piezoelectric ceramic transducer.

cause the higher pressure causes a reduction in τ_{1A} . At the same time, the reduction of τ_{1A} also causes S_{01} in Eq. (2) to reduce. Therefore, $R(\omega)$ in Eq. (2) increases with the enhancement of the air pressure when the system is modulated by a light field whose frequency is lower than ω_c . At the optimal operation point, the best population distribution between the upper and lower levels is achieved. That point corresponds to the largest optogalvanic signal. The shift of ω_c means that the higher modulating frequency is available, which causes discharge noises to have a smaller impact to the optogalvanic current so as to improve the SNR dramatically.

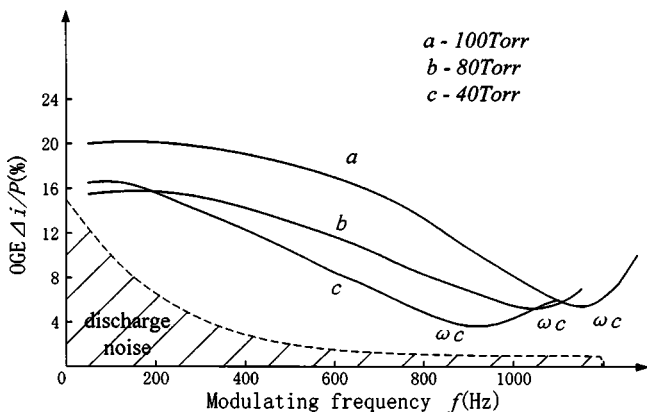

Fig. 2 OGE as a function of modulating frequency and pressure: $\Delta i/P$, OGE change unit power; ω_c , counter spot of frequency; I , operating current—8 mA.

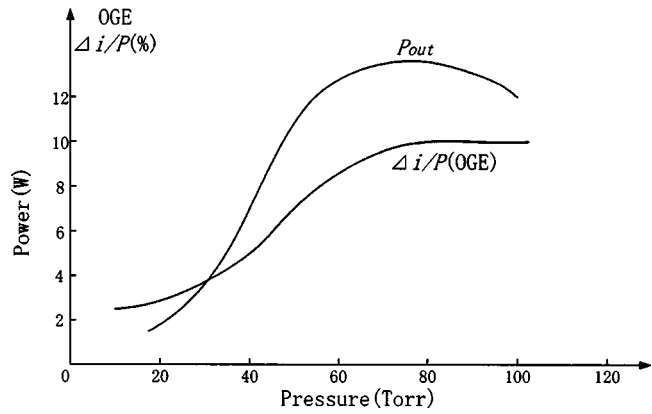

Fig. 3 OGE as a function of pressure and output power: P_{out} , output power; $\Delta i/P$, OGE variation; $I=6$ mA, $f=1000$ Hz.

2.2.2 Relationship of the optogalvanic signals and the discharge conditions

In the measurement for the relationship of optogalvanic signals to the working pressure and the current, Fig. 4 shows that with a change of the working current the optogalvanic signals appear to have a largest value, corresponding to the best working current. Because the best working current has the highest upper level excitation rate and the lower level excitation rate is relatively low, the S_{02} in Eq. (2) is improved greatly. Furthermore, compared with the conventional lasers with equal cavity length, the waveguide laser with much higher air pressure has an obvious advantage on the optogalvanic current because the high air pressure and the low current cause τ_{2A} to increase and τ_{1A} to reduce. Hence, the S_{01} in Eq. (2) reduces sharply and S_{02} increases at the same time. In other words, the total optogalvanic current amplitude $R(\omega)$ increases as well when ω is lower than ω_c .

Obviously, the optogalvanic current characteristics of CO₂ waveguide lasers, such as the high sensitivity, the high amplitude, the high response frequency, and the high SNR, are quite favorable for the frequency stabilization.

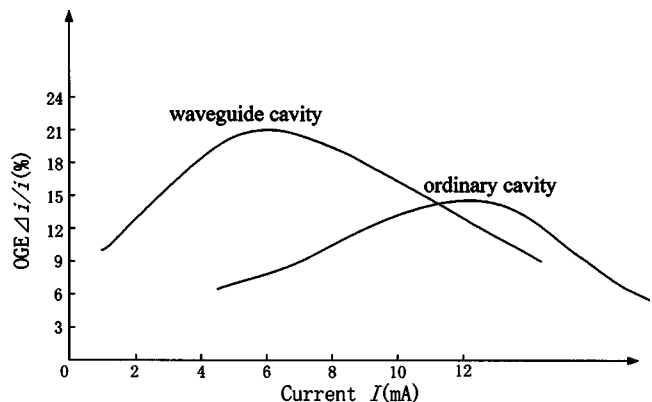

Fig. 4 OGE as a function of operating current and pressure in an ordinary CO₂ laser: pressure $P=30$ Torr; waveguide CO₂ laser, pressure $P=80$ Torr, $f=1000$ Hz.

3 CO₂ Waveguide Lasers Stabilized by OGE and Tuned by the Compound Cavity

3.1 Experimental Setup

Combining our previous study on the CO₂ waveguide lasers with a compound cavity,⁴ we set up a CO₂ waveguide laser system stabilized by the OGE and tuned by the compound cavity. Figure 1 is the general experimental setup including the grating compound cavity tuning and optogalvanic current frequency stabilizing servo control.

3.2 Grating Compound Cavity Tuning (Branch Selection) System

The cavity used for the frequency selection and the tuning of CO₂ waveguide lasers was often investigated by many people. However, some drawbacks exist in the cavities they proposed. For example, the resolution ratio and the coupling efficiencies of the conventional grating cavity are very low and the line-jumping phenomenon occurs in the process of frequency selection. Although the spherical grating cavity has a simple structure and good-quality beams, it is very hard to manufacture the spherical grating with a small radius. A Fox-Smith cavity has a relatively low loss and a high resolution, but its complicated structure and large size compromises the most favorable advantage of the waveguide lasers: miniaturization. Thus we proposed a special cavity for the continuous tuning of the CO₂ waveguide lasers; that is, a compound cavity composed of the grating *G*, the reflective mirrors *M*₁, *M*₂, etc. (see Ref. 4). This type of the cavity not only has a compacted structure, but it also has a high resolution and wide tuning range, and it can also completely avoid the line-jumping phenomenon. References 4 and 5 include a detailed presentation.

For wavelengths stratifying the “Lettor” condition, the grating *G* is equivalent to a cavity mirror. It and partial transmission mirror comprise the “F-P” cavity (coupling cavity), and the “F-P” cavity and the totally reflecting mirror *M*₂ comprise the compound cavity. From the viewpoint of the resonator mirror reflection,⁶ the coupling cavity is equivalent to a reflective mirror with a tunable reflective index *R*_{tot} (Ref. 7):

$$R_{tot} = \frac{(r_1 - r_3)^2 + r_1 r_3 \sin^2 \phi_b}{(1 - r_1 r_3)^2 + 4 r_1 r_3 \sin^2 \phi_b} \quad (4)$$

In Eq. (4), *r*₁ and *r*₂ are the reflective indices of *M*₁ and grating *G*, respectively. The phase displacement Φ_b is $(2\pi/\lambda)L_1$. Hence, for the every spectral line that is chosen through the grating equation $\lambda = 2d \sin i$, the optimal coupling efficiency of the resonator is obtained. Simultaneously, the EH₁₁ mode can be coupled into TEM₀₀ with quite low loss due to *M*₁ being as close as possible to the orifice of the waveguide tube.⁸ A laser with a compound cavity therefore not only has a compact and safe structure, but also achieves continuous tuning and high power operation.

Here *G* is an etched grating with a grating constant 120 lines/mm; the transmissive ratio of *M*₁ is 0.8; *M*₁ and *M*₂ are both planar mirrors; the coupling cavity length *L*₁ is 3 cm and the main cavity length (the distance between *M*₁

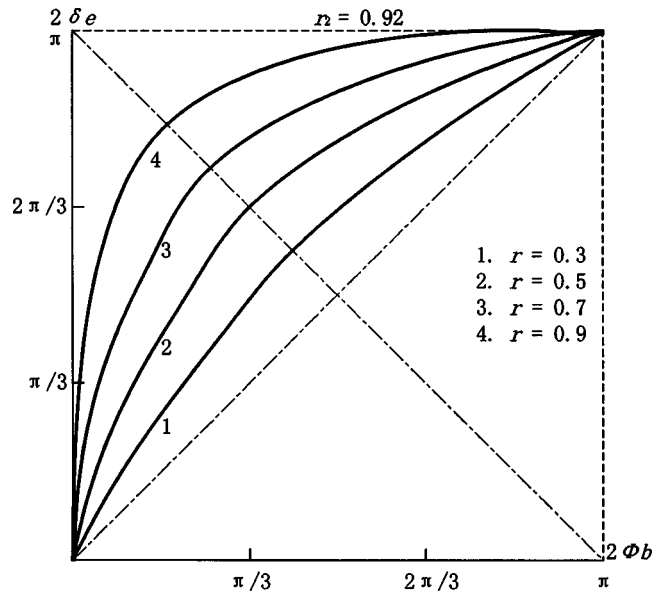

Fig. 5 Equivalent reflectivity *r*₁ and its reflective phase change δ_e as a function of Φ_b .

and *M*₂) is 30 cm. Also, *G* is fixed on the substrate of the grating turret by the piezoelectric ceramic transducer. The branch selection procedure can be completed as follows:

1. The computer controls a stepper motor to rotate the grating so as to select 60 lines from the range of 9 to 11 μm.
2. For the every spectral line, the optimal output is obtained by modulating *L*₁ and controlling the voltage of the piezoelectric ceramic.

On the other hand, based on the principle of the compound cavity mode resonance proposed by Kong et al., the compound cavity phase change Φ_b not only influences the total equivalent reflective index of the compound cavity, i.e., *R*_{tot} in Eq. (4), but also causes⁹ a phase change of the compound cavity oscillating modes δ_e .

$$\tan \delta_e = \frac{(1 - r_1)^2 r_3 \sin 2\phi_b}{(1 + r_1^2) r_3 \cos 2\phi_b - r_1 (1 + r_3)^2} \quad (5)$$

Therefore, the accommodation to *L*₁ means tuning to the wavelengths of the oscillating modes, which is the basis for study of the tuning system.

Figure 5 presents the relationship of curves δ_e and Φ_b as a result of Eq. (5), and shows that there is a sensitive area with the change of Φ_b for an appropriate transmission rate *r*₁ of *M*₁. Figure 6 represents the relationship of the laser output power (corresponding to *R*_{tot} of the compound cavity) and the displacement of the piezoelectric ceramic (corresponding to the coupling cavity length *L*₁). This shows that the modulation to *L*₁ is equivalent to the modulation to the cavity frequency and the field strength of the compound cavity. Similarly, the stability of *L*₁ means the stability of the output power and the oscillating frequency of the compound cavity lasers.

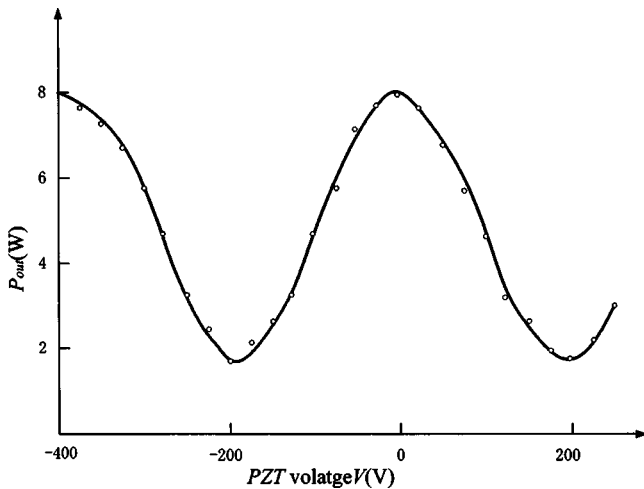

Fig. 6 Output power as a function of displacement of PZT displacement: $\Delta L_1 = 8 \times 10^{-3} \mu\text{m/V}$.

3.3 Optogalvanic Current Frequency Stabilization and Servo Control System

When the compound cavity tuning system finishes the branch selection process, the feedback control system for the optogalvanic current frequency stabilization begins the process of the frequency stabilization. A sinusoidal wave modulation voltage with $f = 1000$ Hz, output from an oscillator, effects the piezoelectric ceramic, which is in an optimal branch selection state, and then the radiation field modulation inside the laser cavity is formed as in Eq. (4) (the modulation quantity of L_1 is ΔL_1 , as in Fig. 6). Simultaneously, this also accompanies the modulation to the central frequency point of the oscillating wavelengths as in Eq. (5). With the influence of outside factors, the variation of the laser cavity causes a corresponding variation of the laser output power and its frequency.¹⁰ In other words, it impacts on the discharge resistance of the discharge tube so as to obtain the corresponding error signals of the optogalvanic current variation.

As shown in Fig. 1, the whole frequency stabilization feedback system includes two parts: the optogalvanic current measurement and the servo feedback control. The optogalvanic current signals from the “ R_0C ” network is amplified by a preamplifier D_1 (gain = 10^4) and then is input into the servo control system. To measure the tenuous signals, we use two series of the synchronic integrator and a series of the correlator for the synchronic integrated circuits and the phase-sensitive wave detection circuits PH, so the system has a good capacity to repress noise. The total gain of this part is higher than 10^4 to reduce as much as possible the modulation quantity ΔL_1 so that the laser operation stability is improved. The circuit's first series Σ drove by the piezoelectric ceramic is the signal synthesis, including the output signals of the phase-locked circuit, the oscillator modulation signals, the computer-control signals, and the voltage bias adjustment. The synthetic signal obtains the ± 400 -V output through the emitter following the differential amplifier D_2 . The gain of the whole servo circuit is 10^6 , the time for the circuit differential is 0.15 to 2 s.

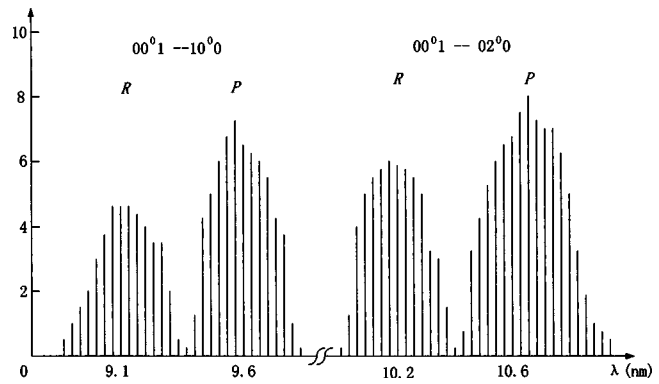

Fig. 7 Observed laser emission spectrum current: $I = 8$ mA; pressure $P = 60$ Torr.

4 Conclusion

We used an advanced computer as the central control system of the whole device (expanding four interfaces and designing the control software) for the processes of the compound cavity branch selection (including the adjustment and the localization of the grating incident angle and the coupling efficiency of the coupling cavity) and the servo feedback control for the optogalvanic current frequency stabilization. The operation sequences are as follows.

First, 60 spectral lines were selected through the whole process of the compound cavity branch selection. They are:

$$00^0 1 \text{ to } 10^0 0: P(12) - P(44), R(14) - R(42),$$

$$00^0 1 \text{ to } 02^0 0: P(14) - P(44), R(16) - R(38).$$

The wavelength range of all the spectral lines is 9.183 to 10.860 μm ; the largest single line [P(22)] power is up to 8 W. Figure 7 represents the output power of the laser spectral lines.

For the each output spectral line in the stable operation state, we used a sinusoidal wave with $f = 1000$ Hz and amplitude ± 50 V (equivalent to $\Delta L_1 = 0.8 \mu\text{m}$) to modulate the coupling cavity length L_1 , and the time for the servo circuit integration is 0.3 s. We measured the each line's power stability in the every spectral band and obtained the power stability average value 0.8% of each output spectral line for a long-term (60-min) operation. Figure 8 shows the output power curve of the line P(18).

For a CO₂ lasers with a single line operation, the resonator length is related to the laser output frequency and the output power. The frequency stability of the computing and analyzing system showed that the preceding frequency selection range of 9 to 11 μm was equivalent to a $\nu = 10^{13}$ MHz laser oscillating frequency. Assuming the average fluctuation value of the system output power as 0.8%, we could estimate the change of the compound equivalent cavity length to be $\Delta L \approx 3 \mu\text{m}$ from Eq. (4) and Fig. 6. Under the condition that the system main cavity length is 30 cm, the corresponding single operation frequency stability is about $\Delta \nu / \nu = 10^{-9}$.

Due to the operation characteristics of CO₂ waveguide lasers, it is so hard to achieve the spectral line tuning and

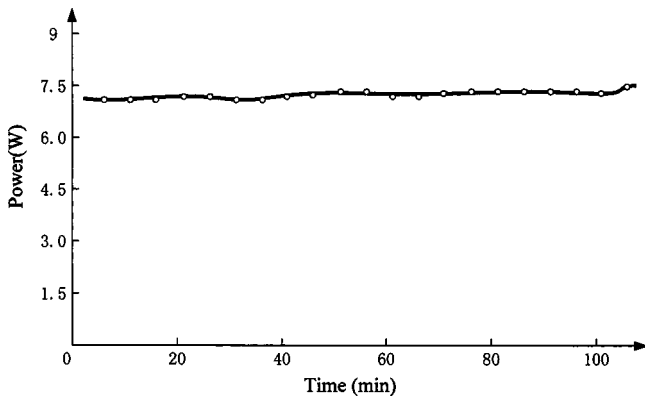

Fig. 8 Single line power stability 00⁰1 to 10⁰0 transition P(22) line, $I=6$ mA.

the line stability simultaneously if we adopt conventional methods, such as the spectrum absorption frequency stabilization method, the lamb-dip stabilization method, etc. Our study shows that the optogalvanic current frequency stabilization and the compound cavity tuning are effective approaches to develop tunable frequency-stabilized CO₂ waveguide lasers. Theoretical and experimental works have proved that the CO₂ waveguide laser has an obvious advantage with respect to the optogalvanic current. The favorable features of the grating compound cavity lie in a low loss on waveguide mode coupling, simple but safe structure, and tunable frequency and power. Just for these reasons, this type of laser system with this combination of these features can not only select out each branch of spectral lines easily, but can also achieve stability of the frequency and power of the spectral lines and attain an optimal power output in the end.

Acknowledgments

The authors are especially grateful to Professor Sailing He for valuable discussions.

References

1. Y. W. Ma and D. Liang, "Study on a phase-locked waveguide array CO₂ laser with a periodic loss distribution," *Opt. Laser Technol.* (in press).
2. A. L. S. Smith and S. Moffatt, "Temperature perturbation model of the opto-galvanic effect in CO₂ laser discharge," *J. Phys. D* **17**, 59–62 (1984).

3. A. L. S. Smith and M. Brooks, "Radiation field induced perturbation in CO₂ laser plasmas," *J. Phys. D* **12**, 1239–1244 (1979).
4. Y. W. Ma and Y. Q. Chen, *The Lasers*, pp. 145–172, Zhejiang University Press, Hangzhou (1999).
5. D. A. Yanson, M. W. Street, S. D. McDougall, L. G. Thayne, J. H. Marsh, and E. A. Avrutin, "Ultrafast harmonic mode-locking of monolithic compound-cavity laser diodes incorporating photonic-bandgap reflectors," *IEEE J. Quantum Electron.* **38**(1), 1–11 (2002).
6. Y. E. See, S. Guha, and J. Falk, "Coupled optical resonator for the enhancement of laser intracavity power," *Appl. Opt.* **20**, 1211–1213 (1981).
7. L. W. Casperson and C. Romero, "Properties of a radial mode CO₂ laser," *IEEE J. Quantum Electron.* **QE-9**, 484–491 (1973).
8. R. L. Abrams, "Coupling losses in hollow waveguide laser resonator," *IEEE J. Quantum Electron.* **QE-8**, 838–842 (1972).
9. Y. F. Kong, Z. Y. Xu, Y. Zhou, D. Q. Deng, X. A. Zhu, and L. A. Wu, "The compound cavity optical parametric oscillator: theory and experiment," *IEEE J. Quantum Electron.* **34**(3), 439–446 (1998).
10. E. A. Avrutin, F. Camacho, A. C. Bryce, C. J. Hamilton, D. Yanson, J. M. Arnold, and J. H. Marsh, "Analysis of monolithic parallel-compound-cavity semiconductor lasers for high brightness, single-frequency, and short pulse operation," in *Summaries of Papers Presented at the Conf. on Lasers and Electro-Optics*, p. 147 (1999).



Yangwu Ma received his BS and MS degrees from the Department of Optical Engineering, Zhejiang University, in 1970 and 1980, respectively, where he began his teaching and research. In his nearly 30 years of research, he published over 60 professional papers and two books and holds three patents. Ma has received many scholastic and provincial research awards. He is currently a senior professor with the Center for Optical and Electromagnetic Research in the Department of Optical Engineering, Zhejiang University, and is a member of Chinese Optical Society (COS). His main research interests are lasers, optical communication, passive and active components, laser medical engineering, and optoelectronics.

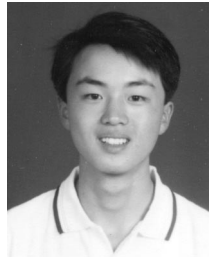

Di Liang is a senior student majoring in optoelectric information engineering and received his BS degree from the Department of Optical Engineering, Zhejiang University, in June 2002. He was originally admitted by the Department of Mechanical Engineering in 1998. A year later, he was qualified to transfer to his major in optoelectric information engineering based on his excellent academic record. Then he entered the Center for Optical and Electromagnetic Research and focused on the study of optoelectronic devices, optical communications, and lasers. He was awarded many academic scholarships by Zhejiang University and several of his papers have been accepted by domestic and international professional journals.