

Heterogeneous Photonic Integration on Silicon

John E. Bowers

*Department of Electrical and Computer Engineering, University of California, Santa Barbara, CA 93106, USA
 bowers@ece.ucsb.edu*

Abstract: We review recent advances in heterogeneous silicon photonic integration technology and components and describe progress in silicon photonic integrated circuits. Techniques for laser integration and the impact of active silicon photonic integrated circuits could have on interconnects, telecommunications and silicon electronics are reviewed. A variety of materials are being heterogeneously integrated, including arsenides for short wavelength lasers, phosphides for infrared lasers, LiNbO_3 for nonlinear applications and YIG for isolators and circulators.

1. Introduction

Eliminating individually aligned single-mode optical connections by integrating optical elements together greatly reduces the optical losses and reflections between the optical elements and leads to reduced cost and size, improved performance, and improved reliability. Photonic integration has recently seen significant advances resulting from improved processing, improved III-V epitaxial crystal growth and advances in heterogeneous integration leading to a wider variety of devices integrated into the photonic integrated circuit (PIC). A discussion is presented of the design and fabrication issues, illustrated by a number of recently demonstrated heterogeneous PICs.

2. Silicon Platform

The use of SOI wafers has a number of advantages, including lower cost and larger wafer size and allowing the use of automated wafer handlers in modern CMOS processing facilities. Si/SiO_2 waveguides have a number of advantages, including low loss and a large index contrast that allows for sharp bends and small waveguide. Si_3N_4 and SiON waveguides on Si substrates have ultralow losses (0.1 dB/m) [1] which enables new applications such as integrated gyroscopes [2] and low linewidth optical and microwave oscillators and sensors [3]. Fig. 1 shows an example of integrating silicon nitride waveguides with silicon waveguides and III-V active elements.

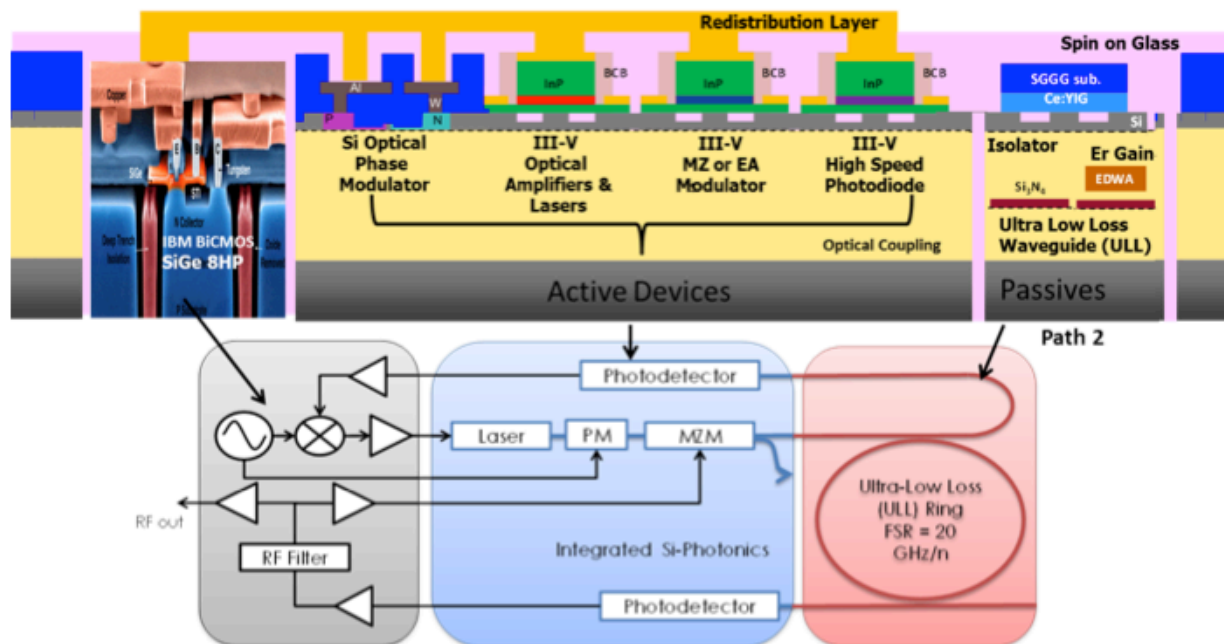

Figure 1: An example of heterogeneous integration to combine low loss Si_3N_4 waveguides with Si waveguides with III-V active elements and electronics to make an optoelectronic oscillator.

3. Heterogeneous Integration

No one material can do everything. Silicon is a great waveguide material, but is not electro-optic, does not have a direct bandgap nor is it nonreciprocal. Heterogeneous integration can combine different materials that are optimized for each of these properties onto one wafer [4]. Heterogeneous integration of III-V gain materials provides high gain necessary for integration of lasers onto PICs, and also makes it possible to combine multiple gain regions together within one PIC. Lasing or spontaneous emission over a broader range of wavelengths than is possible with one gain region has been demonstrated [5]. No longer are we limited to just C or C+L bands. High quality waveguide optical isolators and circulators have been demonstrated by bonding Ce:YIG to silicon [6,7]. Fig. 2 shows a schematic diagram of a structure that has over 30 dB of isolation with low loss. As a final example, LiNbO₃ has also been bonded to Si for efficient doubling of light by using the tight confinement provided by heterogeneous integration to silicon nitride waveguides.

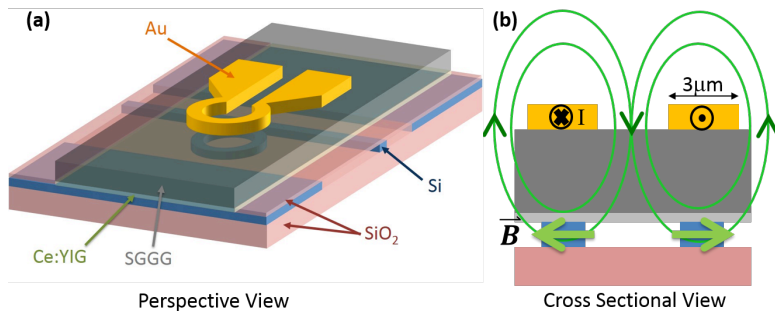

Fig 2ab. Schematic diagram and cross section of a Ce:YIG optical isolator.

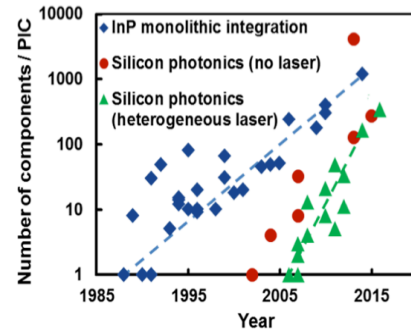

Fig. 3. Photonic Moore's Law: The number of photonic elements integration onto a waveguide versus time.

4. Epitaxial III-V/Si

A number of groups around the world are investigating ways to grow III-V epitaxially on Si and solve the problem of dislocation caused failures [8-11]. The basic problem is that the dislocation density of $10^8/\text{cm}^2$ corresponds to a dislocation every micron, which is a dislocation spaced a diffusion length away. A promising alternative is to use quantum dots with high density, perhaps 500 times the dislocation density [9]. Then, most carriers find a quantum dot rather than a dislocation and the quantum efficiency is much higher. Excellent performance has been obtained, with low thresholds (250 A/cm^2), high powers (176 mW) and high temperature operation (119C) [9]. Further research is needed to increase the lifetimes to acceptable levels.

5. Perspective

The complexity of PICs and the number of elements integrated onto a waveguide is growing rapidly, as shown in Fig. 3, and will continue to do so. With higher levels of heterogeneous integration comes increased capability, and applications in optical interconnects and sensors should follow. Embedded photonics in silicon electronic chips is the ultimate high volume driver for heterogeneous PICs.

6. References

- [1] J. F. Bauters, M. L. Davenport, M. J. R. Heck, J. K. Doylend, A. Chen, A. W. Fang, J. E. Bowers, "Silicon on Ultra-low-loss Waveguide Photonic Integration Platform", *Optics Express*, Volume: 21 Issue: 1 Pages: 544-555, 14, January 2013
- [2] S. Srinivasan, R. Moreira, D. Blumenthal and J. E. Bowers "Design of integrated hybrid silicon waveguide optical gyroscope ", *Optics Express*, Vol. 22 Issue 21, pp.24988-24993; 20 October 2014
- [3] D. Huang, Sudharsanan Srinivasan, J. E. Bowers, "Compact Tb doped fiber optic current sensor with high sensitivity", *Optics Express*; Vol. 23, No. 23; 6 November 2015
- [4] T. Komljenovic, M. Davenport, J. Hulme, A. Y. Liu, C. T. Santis, A. Spott, S. Srinivasan, E. J. Stanton, C. Zhang, and J.E. Bowers, "Heterogeneous Silicon Photonic Integrated Circuits", *Journal of Lightwave Technology*; 06 August 2015
- [5] A. De Groot, J. D. Peters, M. L. Davenport, M. J. R. Heck, R. Baets, G. Roelkens, and J. E. Bowers, "Heterogeneously integrated III-V-on-silicon multibandgap superluminescent light-emitting diode with 290 nm optical bandwidth," *Optics Letters* 39, 4784-4787 (2014)
- [6] P. Pintus, et al. "Integrated TE and TM optical circulators on ultra-low-loss silicon nitride platform," *Optics Express* 21(4) 5041-5052 (2013).
- [7] D. Huang, et al. "Silicon microring isolator with large optical isolation and low loss" *OFC 2016* (2016).
- [8] T. Wang, H. Liu, A. Lee, F. Pozzi, and A. Seeds, *Optics Express* 19, 11381 (2011).
- [9] A. Y. Liu, S. Srinivasan, A. Gossard, J. Norman, J.E. Bowers; "Quantum dot lasers for silicon photonics" *OSA Photonics Research*, Vol:3, Issue: 5, pp B1-B9, 1 October 2015
- [10] Zhechao Wang et al., "Room-temperature InP distributed feedback laser array directly grown on silicon", *Nature Photonics* (2016).
- [11] S. Chen, W. Li, J. Wu, Q. Jiang, M. Tang, S. Shutts, S. N. Elliott, A. Sobiesierski, A. J. Seeds, I. Ross, P. M. Smowton, and H. Liu, "Electrically pumped continuous-wave III-V quantum dot lasers on silicon," *Nature Photonics*, March, 2016.